

Part number

CHP 16 LS



Brief description:

surface mounting housings with single lever, size "77.27", metal cover, Pg21, metal version, IP65

Product description

Version	metal version
Series	surface mounting housings with single lever
Product type	with 1 lever
Variant	metal cover
Family	CLASS enclosures
Size	size "77.27"

Technical data

Material	metal
IP degree of protection	IP65
Cable entry	Pg21

Further technical details

Weight	378,00 g
---------------	----------

Approvals / Standards

Quality mark	 (type:4/4X/12),  , EAC
Conformity	CQC, CE

General ordering information

EAN13 code	8015747022231
Tariff number	85369095

Packaging Information

Packaging length	475,00 mm
Packaging height	180,00 mm
Packaging width	175,00 mm
Packaging weight	3,83 kg
Packaging volume	14,96 dm ³
Packaging description	Carton box
Packaging quantity	10 Pcs
Packaging EAN code	8015747022248
Sub-packaging weight	1,92 kg
Sub-packaging description	Plastic pakaging
Sub-packaging quantity	5 Pcs
Sub-packaging EAN barcode	8015747022255

Part number

CHP 16 LS



Catalogue drawings

CHP L CAP L - MHP L MAP L

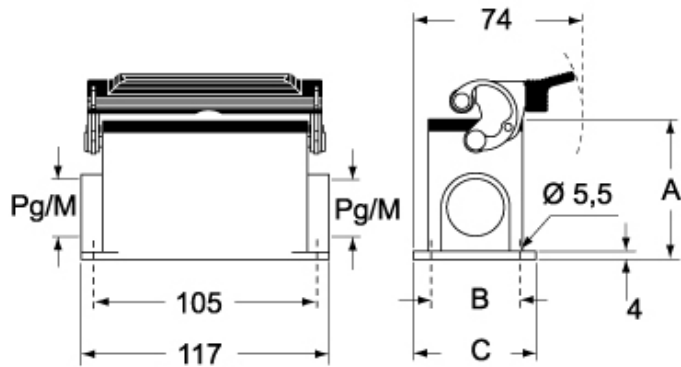

CHP LS CAP LS - MHP LS MAP LS



	A
CHP L / MHP L	63
CAP L / MAP L	77
CHP LS / MHP LS	63
CAP LS / MAP LS	77